

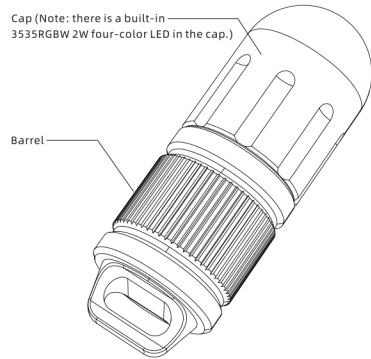

## SD1 4-colour Mini Dive Beacon

Cap (Note: there is a built-in 3535RGBW 2W four-color LED in the cap.)



Barrel

V6

### Introduction

SD1 integrated 4 colour lights and 8 lighting modes. Gently turn barrel to switch modes. Ideal for both underwater 100m diving and outdoor lighting.

### Parameters

Colour lights	white		red		blue		green	
Lighting modes	constant	flashing	constant	flashing	constant	flashing	constant	flashing
Luminance	25lm	/	10lm	/	10lm	/	25lm	/
Runtime (16340 650mAh)	5hrs	10hrs	5hrs	10hrs	5hrs	10hrs	5hrs	10hrs
Impact Resistant	1.5m							
Waterproof	Underwater 100meter							
Size	Ø23mm(Head) x 66mm(Length)							
Net weight	27g (excluding battery)							

### Operation

#### ■ Insert the battery

Unscrew cap, insert a CR123A or a 16340 (protected) Li-ion battery, with the positive pole (+) towards the cap, and then screw tightly.

#### ■ On/off

After installing the battery, tighten cap, LED lights up. To power off, rotate the cap.

#### ■ Change modes

Users can tighten and loosen the SD1 body to swap the modes, it will cycle in "white-white flashing-red-red flashing-blue-blue flashing-green-green flashing modes" by default.

#### ■ Memory function

Power off at any lighting mode, and keep power off > 5s, the last lighting mode will be memorized, when you turn it on, SD01 will start to cycle from the memorized mode by default.

#### ■ Power reminder

When battery level is low, it will auto-downshift its output level to inform the user it is time to charge.

Or, it will automatically turn off 10 minutes later, and enter sleep state.

#### ■ Tips

1. When battery is exhausted or flashlight not in use for a couple of weeks, please take out the battery from the unit;
2. To prolong the lifespan of your flashlight, please use CR123A or a 16340 (protected) Li-ion battery with sufficient energy only;
3. When installing battery, notice carefully the direction of positive and negative poles;
4. Light fails to start

Possible reasons	Solutions
Battery is exhausted or not compatible	Change battery
Battery is installed incorrectly	Make sure the positive pole (+) towards the head
Poor contact	1. Clean the contact surface with alcohol. 2. Tighten the head and tail cap.

If the flashlight still fails to operate, please get the After-sales service.

### After-sales

Please provide warranty number to get after-sales service.

- 15 days free replacement.
- 12 months free repair. If problem developed is beyond 12 months, we will offer free repair service but charge for parts used.
- Lifetime technical support.

#### Note:

1. Damage caused by misuse or intentional abuse is not covered by the warranty.
2. Warranty number (9-13 digits) can be found on the package or product.

Global After-sales Email: [service@xtar.cc](mailto:service@xtar.cc)

#### Anti-fake inquiry

1. Scratch the anti-counterfeiting label on the package to get 18-digit number.
2. Input the number into the query page on [www.xtar.cc](http://www.xtar.cc) (Contact Us - Anti-fake).



**Warning: Do not radiate the light directly towards the eyes, serious injury or blindness could occur by misuse.**



**Company info: Shenzhen XTAR Electronics Co., Ltd**  
 Address: 5th Floor, No.77 Xinhe Rd, Shangmugu, Pinghu Area,  
 Longgang District, Shenzhen, Guangdong, China  
 Zip Code: 518111  
 Website: [www.xtar.cc](http://www.xtar.cc) Email: [info@xtar.cc](mailto:info@xtar.cc)  
 Tel / Fax: +86-755-25507076

Made in China